

# Stereotactic radiosurgery: comparing different technologies

Michael Schwartz, MD, MSc

## Abstract

RADIOSURGERY CAN BE DEFINED as 3-dimensional stereotactic irradiation of small intracranial targets by various radiation techniques. The goal is to deliver, with great accuracy, a large, single fraction dose to a small intracranial target, while minimizing the absorbed dose in the surrounding tissue. This article describes certain technical aspects of radiosurgery and compares the different methods of performing such treatment. The 2 most frequently used types of devices for radiosurgery are units with multiple cobalt sources (e.g., the Gamma Knife) and those based on a linear accelerator. In the former, highly collimated beams of radiation from the cobalt sources intersect at the target. In the latter, the source of a highly collimated beam of high-energy photons directed at the target turns through an arc or set of arcs. The accuracy of target localization, the steepness of fall-off of the radiation dose outside the target and the ability to irradiate an irregularly shaped target are all comparable for these 2 types of devices, despite claims to the contrary.

## Résumé

ON PEUT DIRE QUE LA RADIOCHIRURGIE est une irradiation stéréotaxique tridimensionnelle de cibles intracrâniennes minuscules au moyen de diverses techniques d'irradiation. L'intervention vise à projeter avec une grande précision une seule dose fractionnée importante sur une cible intracrânienne minuscule tout en réduisant au minimum la dose absorbée dans les tissus voisins. On décrit dans cet article certains aspects techniques de la radiochirurgie et on compare les différentes façons de procéder à ces interventions. Les dispositifs les plus utilisés pour la radiochirurgie sont les appareils à sources de cobalt multiples (par exemple, l'appareil Gamma Knife) et les appareils à accélérateur linéaire. Dans le premier cas, des faisceaux de rayons très collimatés provenant des sources de cobalt convergent sur la cible. Dans le deuxième, la source d'un faisceau très collimaté de photons de grande énergie dirigé vers la cible suit un arc ou une série d'arcs. La précision du faisceau sur la cible, l'escarpement de la chute de la dose de rayonnements en dehors de la cible et la capacité d'irradier une cible de forme irrégulière sont des facteurs tous comparables pour ces deux types de dispositifs, en dépit des affirmations contraires.

**O**n Feb. 9, 1997, the CTV television network broadcast a short item on radiosurgery during the national news, presenting the case of a Canadian woman who travelled to the US to undergo the treatment. Two physicians with no experience in the field characterized the radiosurgical treatment available in Canada as "cheap" and "less safe and effective" than treatment with the Gamma Knife (Elekta Instruments Inc., Atlanta), a radiosurgical device available in some countries outside of Canada, including the US. The assertion that radiosurgery performed in Canada is in some way inferior is groundless, and the impression created by the news item is unsupported by scientific evidence. This article describes certain technical aspects of radiosurgery to permit a comparison between the different methods of performing such surgery. The information provided here is in some ways specific to the Toronto-Sunnybrook Regional Cancer Centre, but all Canadian radiation facilities have rigorous quality assurance programs and use similar techniques.



## Education

## Éducation

**Dr. Schwartz is a neurosurgeon at the Sunnybrook Health Science Centre and Associate Professor with the Department of Surgery, University of Toronto, Toronto, Ont.**

*This article has been peer reviewed.*

CMAJ 1998;158:625-8



## Definitions and principles

Radiosurgery can be defined as “three-dimensional stereotactic irradiation of small intracranial targets,” such as arteriovenous malformations (AVMs) and acoustic neuromas, by various radiation techniques.<sup>1</sup> “The goal of each technique is to deliver a large single fraction of radiation to a small intracranial target with great accuracy while minimizing the absorbed dose in the surrounding tissue.”<sup>1</sup>

This goal is accomplished with the aid of a stereotactic frame. The frame has 2 functions: to define a 3-dimensional system of reference containing the patient’s head and the lesion to be treated and to position the head in relation to the radiation device. Any errors inherent in the use of the frame are common to all methods of radiosurgery.

### Radiation required: high dose, steep fall-off

A Gamma Knife unit consists of 201 small cobalt-60 sources distributed evenly over a portion of a sphere. Each source produces a narrow collimated beam of radiation. These beams intersect only at the target point, thus producing a steep radiation-dose gradient<sup>2</sup> (Fig. 1). The rest of the brain receives radiation in proportion to the number of beams passing through it, as well as the scatter from photons that are partly absorbed.

Radiation devices with a single radiation source, such as the linear accelerator (commonly known by the term “linac”), create a high dose at the target point because the source is rotated through an arc or set of arcs (Fig. 2). The radiation beam is directed at the target for the entire treatment time but passes through other parts of the brain only momentarily. The amount of radiation to which any region of the brain (other than the target area) is exposed is proportional to the period of time during which the beam is di-

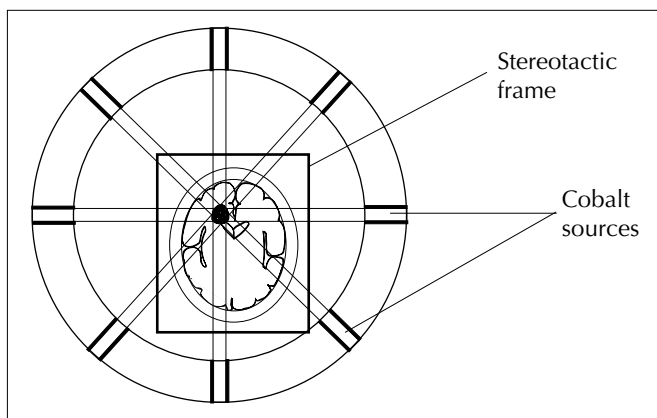

**Fig. 1:** In the Gamma Knife radiosurgery unit, beams from 201 highly collimated cobalt sources intersect at the centre of the hemisphere on which they are arrayed. The patient’s lesion (an arteriovenous malformation or a tumour) is positioned at the point of intersection by means of the stereotactic frame.

rected at that region. In the dynamic rotation system<sup>3</sup> used at McGill University in Montreal and at Sunnybrook, a long single arc is produced by rotating the x-ray source and the patient at the same time. The path that the beam traces on the surface of the head thus resembles the seam of a baseball.

Podgorsak and colleagues have documented the steepness of fall-off of radiation for the Gamma Knife and for a series of different arc patterns produced by linear accelerators.<sup>4</sup> Fall-off was steeper (which is more desirable) when measured in some directions for the Gamma Knife and in other directions for the linear accelerator. For all practical purposes, however, there was no difference.<sup>4</sup>

With a single “shot” from a Gamma Knife or a rotating linear accelerator, the shape of the high-dose radiation volume is spherical. For nonspherical targets, an irregular radiation “footprint” that conforms to the shape of the target is built up by combining a number of spherical doses. The “footprint” may also be modified by occluding selected Gamma Knife sources or by blocking out portions of the arc.

### Accuracy

The relative accuracy of the Gamma Knife and the linear accelerator in delivering radiation to the target has been a contentious issue. It has been argued that because the Gamma Knife has multiple static sources, it is more accurate than the linear accelerator, which has moving parts, but this assertion is simply not true. Claims of sub-millimetre accuracy for either system ignore the potential errors and uncertainties associated with imaging, target choice, dose calculation, the spatial accuracy of the radiation device and setup (the positioning of the patient relative to the radiation device). However, all studies on accu-

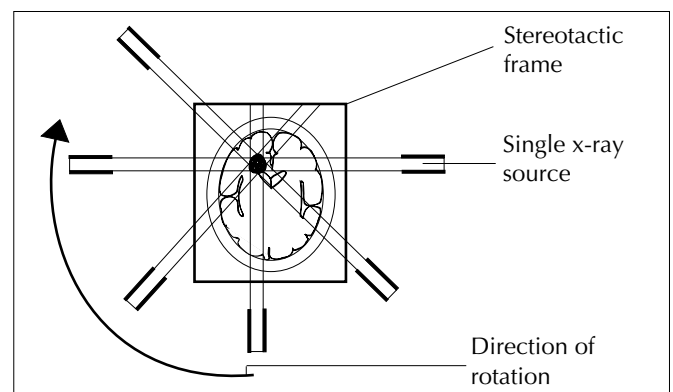

**Fig. 2:** A diagram of a rotating linear accelerator shows successive positions of the high energy x-ray source as it rotates about the lesion. After one arc of rotation has been completed, the patient may be rotated about the lesion in the plane perpendicular to the arc of rotation, and rotation of the x-ray source repeated. In the dynamic method, both the x-ray source and the patient rotate about the lesion simultaneously, which results in a single, long arc.



racy agree that once a target has been defined, the limiting factors are imaging and setup.<sup>5</sup>

All types of imaging involve some degree of potential error. For example, spatial distortion occurs in digital angiography and in MRI. Although such distortion is less of a problem with CT, even current models of CT scanners have a limit of resolution greater than the 0.1 to 0.3 mm accuracy claimed for certain radiation devices.<sup>6</sup>

During a study at the Sunnybrook centre (unpublished data) several physicians independently looked at a series of tumour types that usually have better-defined margins than arteriovenous malformations (AVMs) and for which it is therefore easier to plan treatment. The inter- and intra-observer error in radiation planning was then calculated. Inter-observer error in choosing the centre of the tumour to be radiated was greater than 1 mm. The participants even chose different collimator sizes to encompass the lesions. Clearly, target definition remains an important limiting factor for precision radiosurgery.

Phantoms containing photographic film or arrays of other radiation detectors are useful for quality assurance because they measure the final distribution of the radiation produced with all the sources of error in play. Devices developed at our centre<sup>6,7</sup> have been used to evaluate the accuracy of treatment at Sunnybrook, McGill University and the University of Western Ontario. Phantoms containing photographic film have shown excellent correlation between the planned and measured isodose lines.<sup>8</sup>

The importance of characterizing a radiation device in a way that assesses all of the potential errors — imaging, target choice, dose calculation, spatial accuracy of the radiation device and setup — cannot be overemphasized.

## Quality assurance

Immediately before every radiosurgery treatment at Sunnybrook, a quality assurance protocol is followed to ensure the accuracy of the laser beams used for the setup and the mechanical accuracy of the radiosurgical device. The localization plates with the coordinates of the selected target are prepared and then checked by 2 different members of the team. Sunnybrook follows a strict schedule for all aspects of quality assurance that meets or exceeds standards suggested by the American Association of Physicists in Medicine.<sup>9</sup>

## Comparing the systems

### *Technical advantages and disadvantages*

The Gamma Knife unit has the advantage of simplicity and lack of movement while radiation is being administered. In effect, the cobalt sources, which emit radiation constantly,

are simply uncovered and re-covered so that an appropriate dose is given. In contrast, the production of high-energy photons by a linear accelerator relies on complex electronics and moving parts that require careful maintenance.

If homogeneity of radiation dose within the target tissue is considered desirable, it may be achieved more easily with larger collimators. For example, staff at Sunnybrook have characterized collimators up to 3.5 cm in diameter for our linear accelerator units. In contrast, the Gamma Knife has a maximum collimator size of only 1.8 cm.

### **Cost**

Although it can reasonably be assumed that the cost of site preparation for the 2 systems is roughly equivalent, calculation of acquisition and operating costs is complex, and the figures given here are therefore approximate.

A 1995 report<sup>10</sup> estimated the purchase price of a Gamma Knife unit at Can\$4.2 million. Annual quality control costs were given as \$11 000, and the cost of replenishing the cobalt sources every 10 years as \$700 000. The cost of disposing of the spent radioactive sources was not estimated. The annual cost of this device, which can be used only for radiosurgery, amortized over 10 years (as suggested by the manufacturer), would be \$491 200.

The cost of a new 6 MV linear accelerator varies according to selected options, but a typical unit might cost Can\$1 million. Likewise, maintenance costs vary widely. At Sunnybrook, a large cancer centre with a capable electronics group, annual maintenance costs were only 3.5% of the capital cost in 1996–97, but annual full-service contracts can run as high as 10%. A representative figure for annual maintenance and operation might therefore be \$75 000. If the device is used exclusively for stereotactic radiosurgery and if for comparison the cost is amortized over 10 years, then the annual expense would be \$185 000. If, however, the linear accelerator is also used for conventional radiotherapy, as is the case in all Canadian centres performing radiosurgery, then the annual cost of radiosurgery should probably be estimated as the proportion of time for which the machine is used for radiosurgery plus the extra costs of special quality assurance measures. Such costs would not likely exceed 10% of the annual cost of acquiring and operating a Gamma Knife unit. The annual cost of radiosurgery with a linear accelerator could be twice that amount for a “turn-key” package amortized over 10 years.

### **Equivalence**

A photon is a photon is a photon. Radiation therefore has the same biological effect regardless of whether the photons emanate from a cobalt nucleus, a linear accelerator target atom or a distant star. Properly calibrated radia-



tion devices intended for radiosurgery, of whichever type, can be made to produce identical patterns of radiation. There is no reason to imagine that the therapeutic or toxic effects of the radiation would differ.

The likelihood of success in the treatment of AVMs by radiosurgery varies directly with the dose of radiation administered and inversely with the diameter of the lesion.<sup>11</sup> In reviewing cases managed at the Sunnybrook centre, my colleagues and I calculated an index derived by dividing the marginal dose of radiation (in grays) by the diameter of the AVM (in centimetres). We then devised an equation to predict the probability of success of treatment.<sup>11</sup> We also obtained data from the centre in Sheffield, England, where more than 2000 patients with AVMs have been treated with a Gamma Knife unit. For a cohort of 394 patients who were followed long enough to assess occlusion or patency of the AVM, the prediction equation had virtually the same parameters as those derived from the Sunnybrook patients, confirming what one would expect: equivalent radiation, equivalent effect.

It is fair to say that the place of radiosurgery is less well defined in the treatment of acoustic neuromas than in the treatment of AVMs.<sup>12</sup> In elderly people, the majority of acoustic tumours may not grow.<sup>13</sup> Therefore, to claim a 94% response rate<sup>14</sup> when 80% of the tumours are not growing is not the triumph it first appears to be. The early experience from Sweden<sup>15</sup> called for radiation doses as high as 25 to 35 Gy at the margin of the tumour. However, control rates were still imperfect and the rate of complications was substantial. More recent radiosurgical treatment of acoustic neuromas has involved marginal doses as low as 16 Gy<sup>12</sup> and 12 Gy (unpublished data), but the follow-up period for the new low doses has been short. Lower marginal doses will almost certainly lead to worse tumour control but fewer complications.

Fractionation of stereotactic radiosurgical treatment with a linear accelerator has recently been reported from Harvard University.<sup>16</sup> Fractionated stereotactic radiotherapy seems to offer excellent tumour control, although the median follow-up period was relatively short (only 26 months). The authors reported virtually no toxic effects on normal structures adjacent to the treated tumours. Fractionated stereotactic radiotherapy given according to a protocol similar to that published by the Harvard group has already been implemented at McGill University and at 3 Ontario radiosurgery units: Sunnybrook, Princess Margaret Hospital and the University of Ottawa. Collaboration among these centres allows us to pool our experience and affords optimal treatment and follow-up for Canadian patients.

## Operator skill

In the end, the application of any technology is dependent

on operator skill. If a patient chooses to have his acoustic neuroma excised in Hanover, Germany, or to undergo surgery on an AVM in Phoenix, there can be no objection. Similarly, a patient may elect to undergo radiosurgical treatment in Providence or Pittsburgh, in the expectation of a better result than she might experience at home in Canada because of the particular experience of the physicians at those centres. Freedom to seek equivalent treatment outside Canada, certainly. But not at public expense.

## Conclusion

Multiple cobalt source units and linear accelerators modified for radiosurgery produce comparable patterns of radiation. That the Gamma Knife has been used longer for radiosurgery is true, but the notion that it is "better" is based on no evidence.

I gratefully acknowledge the help of my radiosurgery colleagues: Peter O'Brien, physicist, and Charlene Young and Phillip Davey, radiation oncologists, who offered advice and criticism in the preparation of this document.

## References

- Larson DA, Gutin PH. Introduction to radiosurgery. *Neurosurg Clin N Am* 1990;1(4):897-908.
- Walton L, Bomford CK, Ramsden D. The Sheffield stereotactic radiosurgery unit: physical characteristics and principles of operation. *Br J Radiol* 1987;60:897-906.
- Podgorsak EB, Olivier A, Marina P, Lefebvre PY, Hazel J. Dynamic stereotactic radiosurgery. *Int J Radiat Oncol Biol Phys* 1988;14:115-26.
- Podgorsak EB, Pike GB, Olivier A, Marina P, Souhami L. Radiosurgery with high energy photon beams: a comparison among techniques. *Int J Radiat Oncol Biol Phys* 1989;16:857-65.
- Winston K, Lutz W. Linear accelerator as a neurosurgical tool for stereotactic radiosurgery. *Neurosurgery* 1988;22(3):454-64.
- Ramani R, Ketko MG, O'Brien PF, Schwartz ML. The QA phantom for dynamic stereotactic radiosurgery: quantitative measurements. *Med Phys* 1995;22(8):1343-6.
- O'Brien PF, Fung A. Measured spatial accuracy for linac-based radiosurgery. *Med Phys* 1994;21(7):1145-7.
- Ramani R, O'Brien PF, Davey P, Schwartz ML, Young CS, Lightstone AW, et al. Implementation of multiple isocentre treatment for dynamic radiosurgery. *Br J Radiol* 1995;68:731-5.
- Schell MC, Bova FJ, Larson DA, Leavitt DD, Lutz WR, Podgorsak EB, et al. Report of Task Group 42, Radiation Therapy Committee. In: *Stereotactic radiosurgery*. (Published for the American Association of Physicists in Medicine.) New York: American Institute of Physics; 1995.
- Technology report: stereotactic radiosurgery*. Oak Brook (IL): University Hospital Consortium Services Corp; 1995.
- Schwartz ML, Sixel K, Young C, Kemeny A, Forster D, Walton L, et al. Prediction of obliteration of arteriovenous malformations after radiosurgery: the obliteration prediction index (OPI). *Can J Neurol Sci* 1997;24(2):106-9.
- Pollock BE, Lunsford LD, Kondziolka D, Flickinger JC, Bissonette DJ, Kelsey SF, et al. Outcome analysis of acoustic neuroma management: a comparison of microsurgery and stereotactic radiosurgery. *Neurosurgery* 1995;36(1):215-24.
- Deen HG, Ebersold MJ, Harner SG, Beatty CW, Marion MS, Wharen RE, et al. Conservative management of acoustic neuroma: an outcome study. *Neurosurgery* 1996;39(2):260-6.
- Norén G, Greitz D, Hirsch A, Lax I. Gamma Knife surgery in acoustic tumours. *Acta Neurochir* 1993;58(Suppl):104-7.
- Norén G, Arndt J, Hindmarsh T. Stereotactic radiosurgery in cases of acoustic neuroma: further experiences. *Neurosurgery* 1983;13:12-22.
- Varlotto JM, Shrieve DC, Alexander E, Kooy HM, Black PM, Loeffler JS. Fractionated stereotactic radiotherapy for the treatment of acoustic neuromas: preliminary results. *Int J Radiat Oncol Biol Phys* 1996;36(1):141-5.

**Reprint requests to:** Dr. Michael Schwartz, Sunnybrook Health Science Centre, 2075 Bayview Ave., Toronto ON M4N 3M5; fax 416 480-6085; m.schwartz@utoronto.ca